



FIRE DAMPERS / SHUTTER TYPE

FIRE DAMPERS

FD-10 STATIC FIRE DAMPER

DFD-10 DYNAMIC FIRE DAMPER

UL555 1 ½ HOUR RATING



FD/DFD-10 DESIGN & CONSTRUCTION FEATURES

Description

Model FD/DFD-10 is a fire damper approved for installation in walls with a fire resistance rating of less than 3 hours. This damper installed vertically in HVAC systems that automatically shut down in the event of fire.

Construction

Frame : Roll formed, galvanized steel
Blades : Low profile roll formed, galvanized steel

Features

Stainless steel closure springs
Fusible links [165°F (74°C) standard]
Vertical Mount

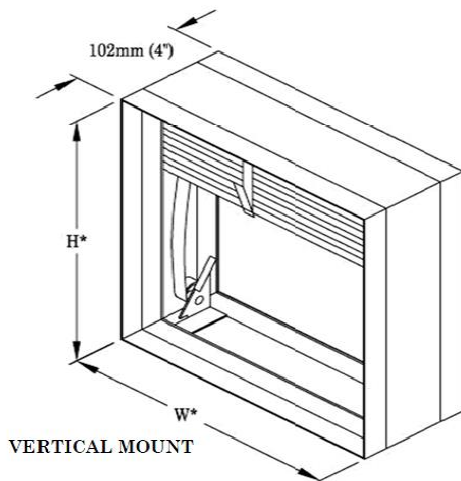

Dynamic Curtain Fire Damper

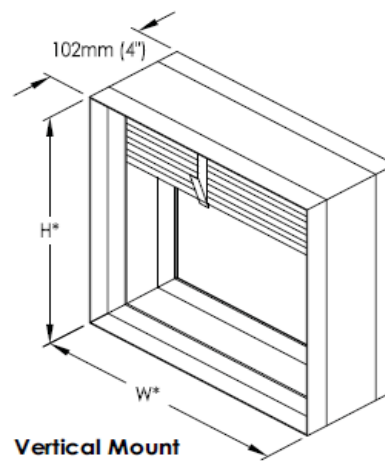

Static Curtain Fire Damper

Optional Features

Sealed transitions and sleeves
One piece retaining angle (POC)
Transitions (A,B,C & CR)

FIRE DAMPERS / SHUTTER TYPE

Factory Sleeve Option

Fire dampers are available in factory furnished sleeves. Sleeves are galvanized steel and are available in 1,0mm – 1,5mm thicknesses and lengths up to 914mm. “C” dimension specifies location of damper within the sleeve. Minimum is 102mm; Maximum is “L” less 102mm, which allows for mounting angle installation and duct connection at each end of sleeve. If “C” dimension is not specified, it will be provided as one half of “L” dimension (damper centered in sleeve).

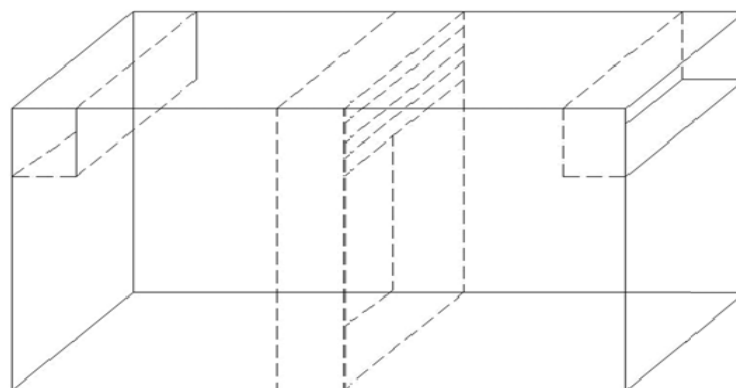
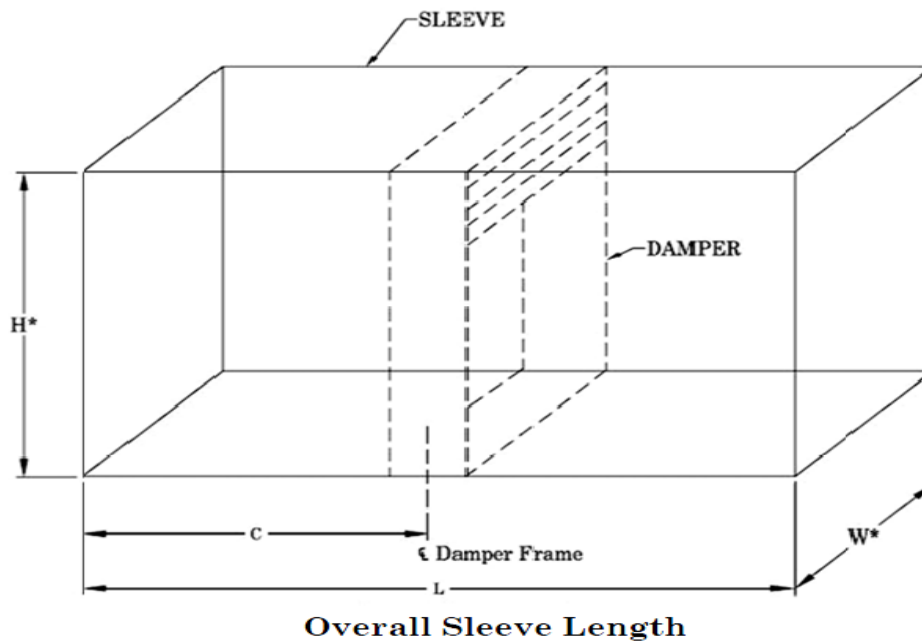

Type B with Sleeve

FD/DFD-10 TRANSITIONS AND SIZE LIMITATIONS

Transition Details

TYPE A		TYPE B	
H*	S	H1*	H2*
102 (4")	20	102 (4")	152 (6")
127 (5")	20	127 (5")	178 (7")
152 (6")	23	152 (6")	203 (8")
178 (7")	28	178 (7")	229 (9")
203 (8")	30	203 (8")	254 (10")
229 (9")	33	229 (9")	279 (11")
254 (10")	33	254 (10")	305 (12")
279 (11")	36	279 (11")	330 (13")
305 (12")	41	305 (12")	356 (14")
330 (13")	43	330 (13")	381 (15")
356 (14")	46	356 (14")	406 (16")
381 (15")	46	381 (15")	457 (18")
406 (16")	51	406 (16")	483 (19")
432 (17")	53	432 (17")	508 (20")
457 (18")	56	457 (18")	533 (21")
483 (19")	58	483 (19")	559 (22")
508 (20")	61	508 (20")	584 (23")
533 (21")	66	533 (21")	610 (24")
559 (22")	66	559 (22")	660 (26")
584 (23")	69	584 (23")	686 (27")
610 (24")	74	610 (24")	711 (28")
635 (25")	79	635 (25")	737 (29")
660 (26")	81	660 (26")	762 (30")
686 (27")	81	686 (27")	787 (31")
711 (28")	84	711 (28")	813 (32")
737 (29")	86	737 (29")	838 (33")
762 (30")	91	762 (30")	864 (34")
787 (31")	94	787 (31")	889 (35")
813 (32")	94	813 (32")	914 (36")
838 (33")	99		
864 (34")	99		
889 (35")	104		
914 (36")	107		

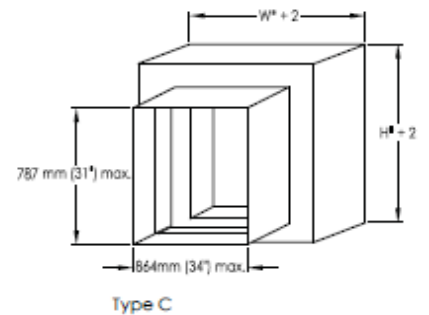
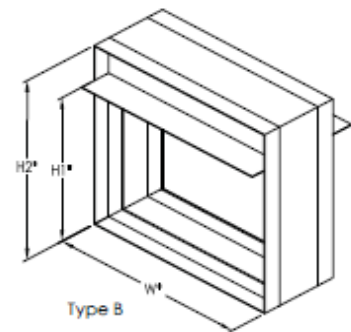
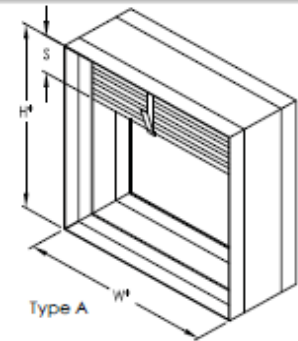

FIRE DAMPERS / SHUTTER TYPE

Size Limitations

VERTICAL SINGLE SECTION SIZE W X H, in (mm)				
TYPE	A	B	C	CR
MINIMUM	4" x 4" (102 x 102)	4" x 4" (102 x 102)	3" x 3" (76 x 76)	3" (76)
MAXIMUM	36" x 36" (914 x 914)	36" x 32" (914 x 813)	34" x 31" (864 x 787)	31" (787)

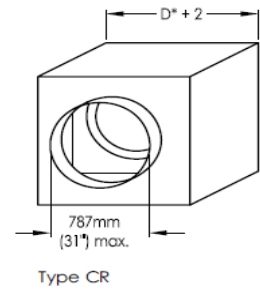

FD/DFD-10 OPTIONS AND ACCESSORIES INSTALLATION

Gauges and Lengths of Fire Damper Sleeve

All fire Dampres must be installed in a steel sleeve of the required gauge and length. See table below for required minimum sleeve gauges. Maximum sleeve thickness is 10 gauge (3,5mm). Sleeve inside dimensions must equal damper out side dimensions. Sleeves shall extend a maximum of 6in. (152mm) beyond the wall opening on each side (see Figure 1)

Sleeve Gauge	Duct Dimension	Types of Duct to Sleeve Connections Permitted
14 Ga. - 10 Ga. (2 mm - 3,5 mm)	All duct sizes	Rigid or Breakaway
16 Ga. 1,5 mm	36 in (914 mm) max. width 24 in (610 mm) max. height 24 in (610 mm) diameter	Rigid or Breakaway
16 Ga. 1,5 mm	All duct sizes	Breakaway only
20 Ga. (0,91 mm)		

Sleeve thickness must not be less than gauge of the connecting duct. UL standard require that all ducts to terminate at fire damper. All sleeve types and thicknesses are needed in the installation instructions & being field supply.

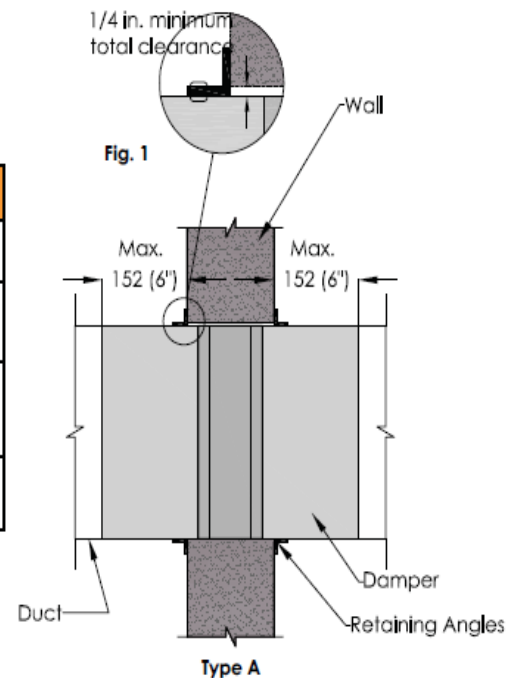

Attaching Fire Dampers to Sleeves

Fire dampers must be attached to sleeves as shown in Figure 2. All four sides of the damper frame must be attached to the sleeve with one row of attachments on each side the blade channel. Attachments must be spaced a maximum of 4 in. (102mm) on centers and a

FIRE DAMPERS / SHUTTER TYPE

in. (25mm). (See Figure 3). Retaining angle legs may be reversed with leg of retaining angle with annular space of opening so angle and sleeve flush against barrier.

- Retaining angles shall not be attached to the sleeve with a tack, spolt weld or rivets. 3/4x10 screws and 1x10 bolts and nuts. The corners shall be attached at the corners with one rivet.
- Retaining angles should not be fastened to the wall material. The angles should only sandwich the wall and allow for damper/sleeve expansion during periods of intense heat.

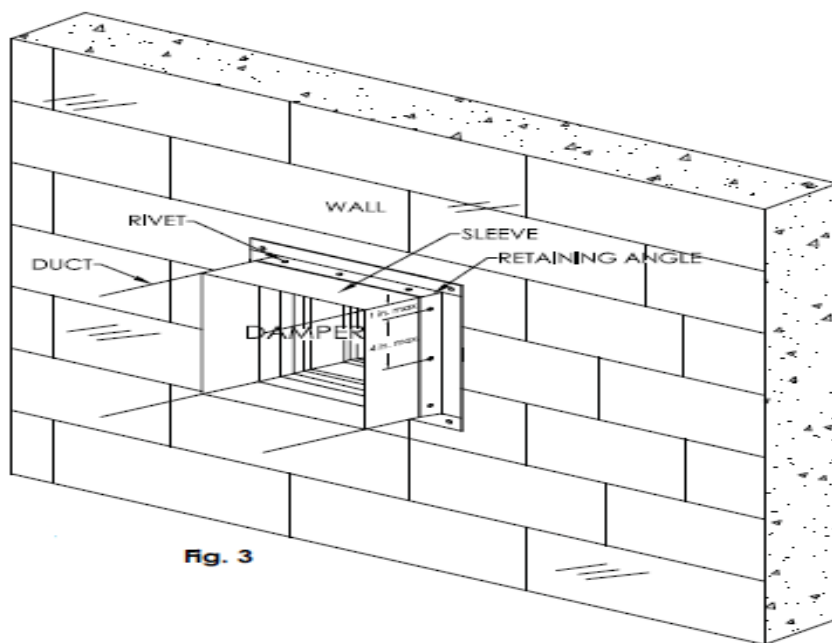



Connecting Ducts to Fire Damper Sleeves

Any duct connection other than breakaway is considered rigid. The connections shown are considered breakaway. Factory furnished duct collars on type R and CR fire dampers are also considered breakaway.

Duct – Sleeve Connections

Traditional Breakaway Style Transverse Joints Transverse joints illustrated have always been approved as breakaway connections. SMACNA testing has also approved the following variations as breakaway connections. Breakaway connections shall have no more than two #10 (4.8mm diameter) sheet metal screws on each side and on the bottom located in the center of the slip pocket and shall penetrate both sides of the slip pocket (applicable to the Plain “S” Slip and Hemmed “S” Joint). Transverse joint can be applied as top and bottom joints with Drive Slip – side joints in duct heights up to 20 in. (508mm)

FIRE DAMPERS / SHUTTER TYPE

Plain "S" Slip	
Drive Slip Joint	
Hemmed "S" Slip Joint	

ORDER PARAMETERS:

FD-10	F00	01	L1200	N 1000X700
FD-10: Static Fire Damper, 74°C Fusible links DFD-10: Dynamic Fire Damper, 74°C Fusible links				N: Neck Size D: Neck Diameter
				L: Requested Product Length
F00: No Flange F30: Flange Width = 30mm F35: Flange Width = 35mm			00: Standard Duct Connection 01: Through Wall Connection	