

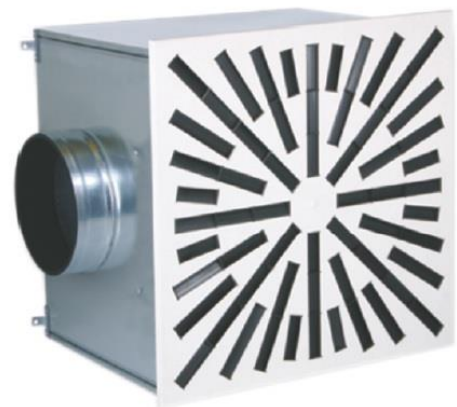

SWIRL DIFFUSER



Swirl Diffusers



SWD124

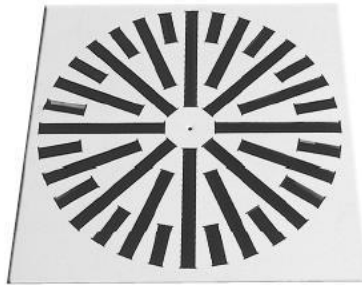

SWD224

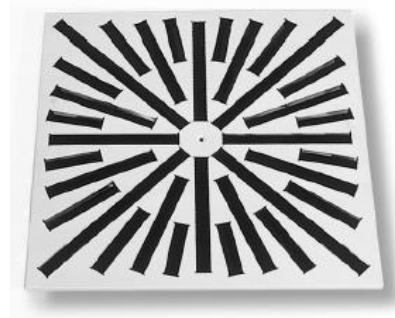

SWD324

DESCRIPTION:

Ceiling swirl diffusers in air conditioning systems create a swirl to supply air to rooms. The resulting airflow induces high levels of room air, thereby rapidly reducing the airflow velocity and the temperature difference between supply air and room air. Ceiling swirl diffusers allow for large volume flow rates. The result is a mixed flow ventilation in comfort zones, with good overall room ventilation, creating only very little turbulence in the occupied zone.

SWD124: Swirl diffuser with adjustable and circular arranged blades and circular front plate

SWD224: Swirl diffuser with adjustable and circular arranged blades and square front plate

SWD324: Swirl diffuser with fixed and square arranged blades and square front plate

MATERIAL:

Sheet metal front plate and plastic blades

FUNCTION:

SWD series swirl diffuser, type is used for the supply and return of cooled and heated air in facilities such as office, shops, meeting room, cinemas, and with height between 2.60m and 4.00m. And with special arrangement of blades it is possible to use heights up to 6m. The air pattern can be adjusted to meet different local requirements. Horizontal air discharge is one-way, two-way or omni directional. Vertical air discharge is possible but only for heating. The supply air to room air temperature difference may range from -14K to $+12\text{K}$.

FINISHING:

- Powder coated in RAL9010 color as standard.
- Other colors on request

INSTALLATION :

SWIRL DIFFUSER

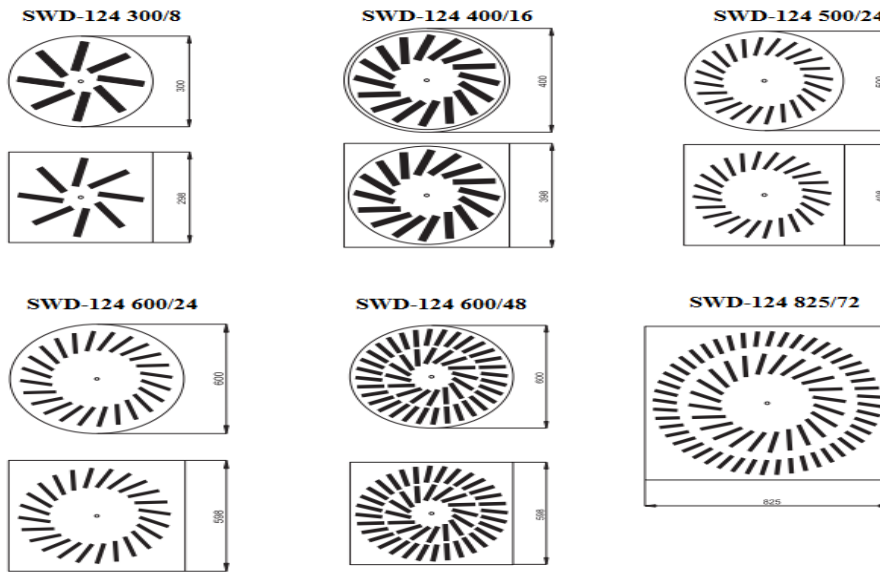

SWD-224 STANDARD SELECTION TABLE

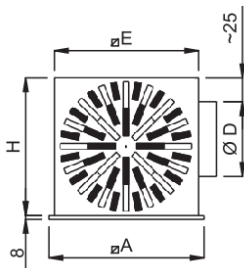

Standard size	A	E	H	D	(V _{min} -V _{max}) Air Volume (m ³ /h)	V(volume) 40db A
310	308	290	260	158	155-410	280
400	398	370	260	158	170-490	330
500	498	470	300	198	300-960	540
600	598	570	350	248	410-1430	810
625	623	570	350	248	410-1430	810
800	798	770	455	353	610-2600	1200

SWIRL DIFFUSER

Blade position 1

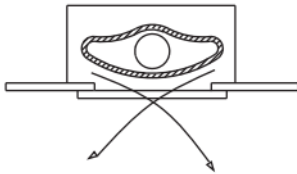

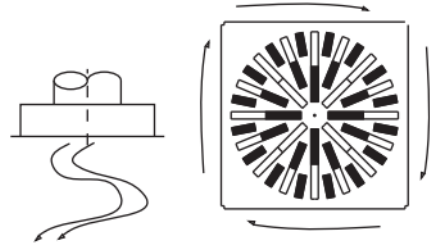

All air control blades set to external swirl

-  Blade position 1
-  Blade position 2



Air flow is orientated in one direction by blades

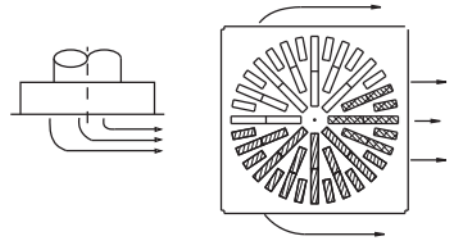

-  Blade position 2, Left
-  Blade position 2, Right
-  Closed

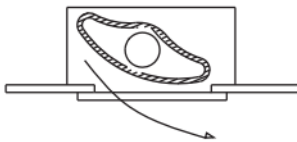

Blade position 2



Air flow is orientated in two direction by blades.

-  Blade position 2, Left
-  Blade position 2, Right
-  Closed

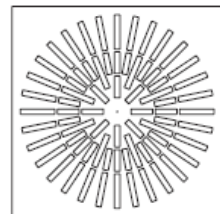
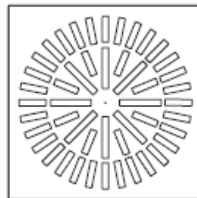
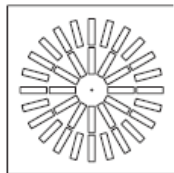
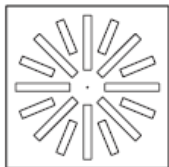
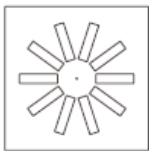
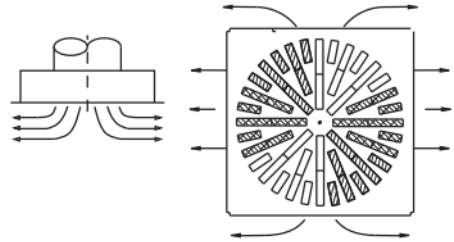

SWIRL DIFFUSER

SWD-324 STANDARD SELECTION TABLE

Standard size	A	E	H	D	(V _{min} -V _{max}) Air Volume (m ³ /h)	V _{volume} 10db A
310	308	290	260	158	160-420	290
400	398	370	260	158	170-610	345
500	498	470	300	198	370-1160	650
600	598	570	350	248	420-1600	890
625	623	570	350	248	420-1600	890
800	798	770	455	353	620-3060	1420

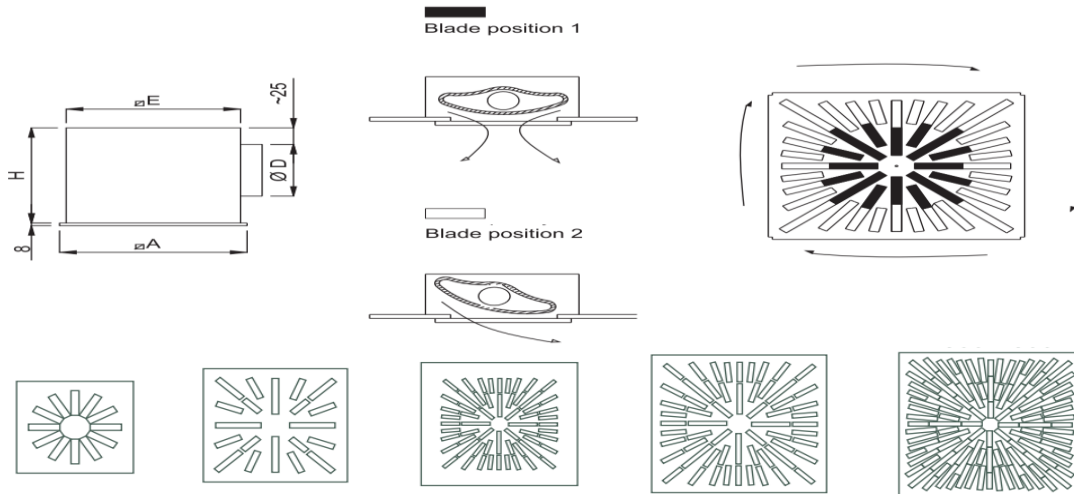

Imperial System

RSD - RADIAL SLOT DIFFUSER

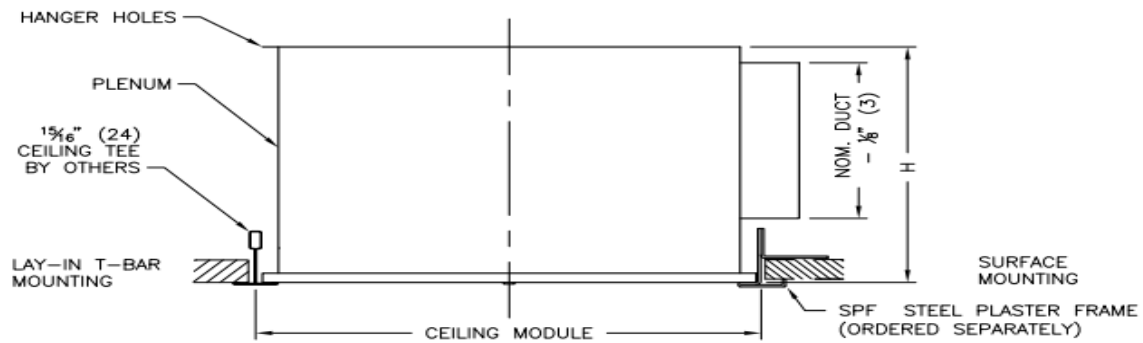

□ SQUARE ARRAY

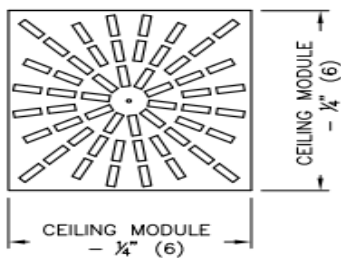

□ CIRCULAR ARRAY

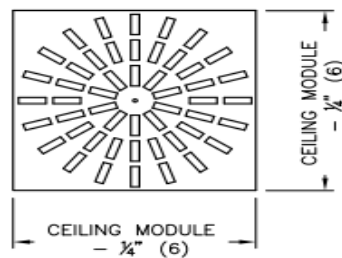

CEILING MODULE	NOM. DUCT	H
----------------	-----------	---

SWIRL DIFFUSER

24" X 24" (600 x 600)	8" , 10" , 12" (203 , 254 , 305)	14" (356)
--------------------------	-------------------------------------	--------------

SWD124 Plenum Box Details:

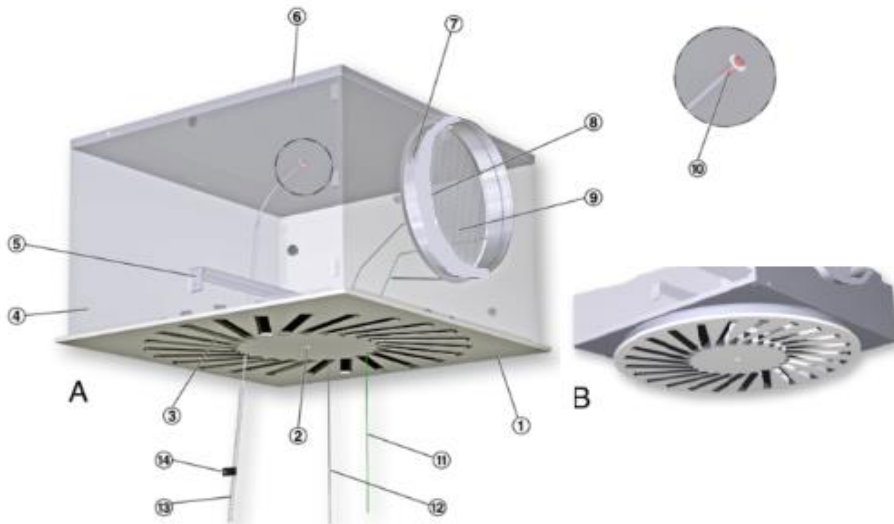

SWD124 A: Square front plate

SWD124 B: Circular front plate

- | | |
|--|--|
| <ul style="list-style-type: none"> ① Diffuser face ② Central fixing screw ③ Adjustable air control blades ④ Plenum box ⑤ Cross bar (bridge) ⑥ Suspension hole ⑦ Spigot Optional | <ul style="list-style-type: none"> ⑧ Lip seal Optional ⑨ Damper blade for volume flow rate balancing-Optional ⑩ Pressure tap - Optional ⑪ Green cord for closing the damper blade ⑫ White cord for opening the damper blade ⑬ Measuring tube ⑭ Text label indicating plenum box variant |
|--|--|

SWD224/324 Plenum Box Details:

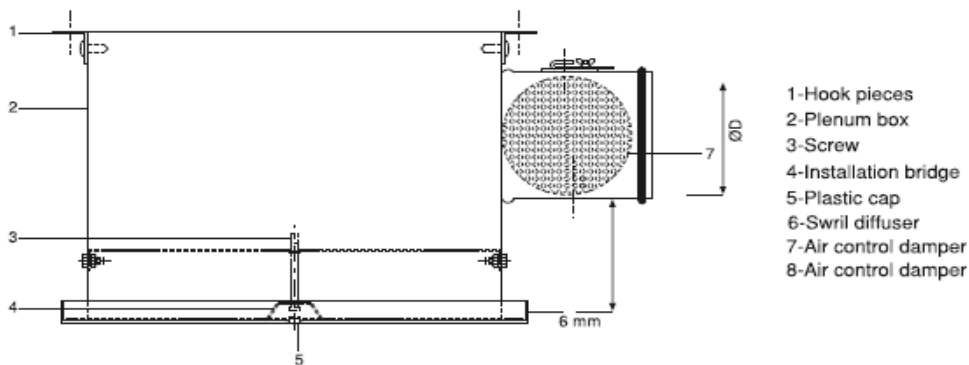

- 1-Hook pieces
- 2-Plenum box
- 3-Screw
- 4-Installation bridge
- 5-Plastic cap
- 6-Swiril diffuser
- 7-Air control damper
- 8-Air control damper

SWIRL DIFFUSER

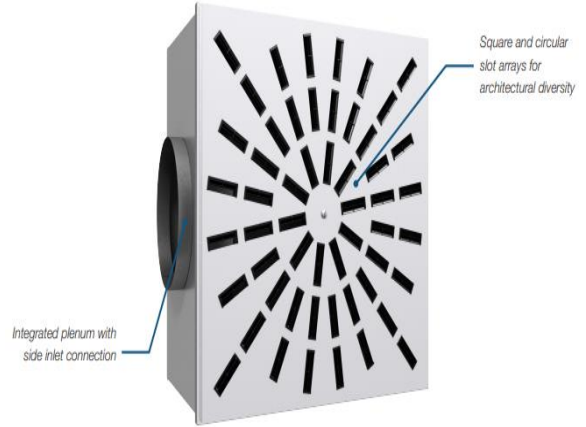
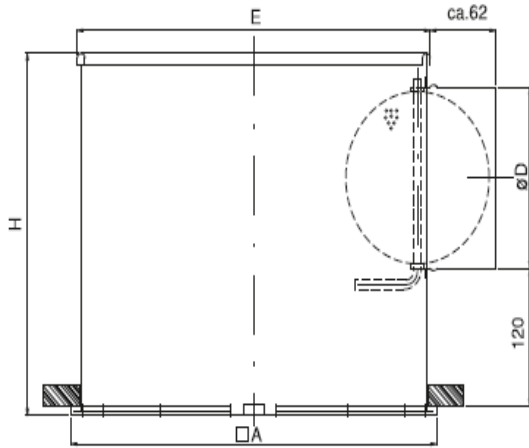

SWD124 SELECTION TABLE

Nominal sizes	300, 400, 500, 600, 625, 825 mm
Minimum volume flow rate, with $\Delta t_z = -6$ K	7 – 99 l/s or 25 – 357 m ³ /h
Maximum volume flow rate, with $L_{WA} \cong 50$ dB(A)	80 – 470 l/s or 288 – 1692 m ³ /h
Supply air to room air temperature difference	-12 to +10 K

SWIRL DIFFUSER

Nominal size	\dot{V} l/s	\dot{V} m ³ /h	Damper blade position					
			0°		45°		90°	
			Δp_t Pa	L_{WA} dB(A)	Δp_t Pa	L_{WA} dB(A)	Δp_t Pa	L_{WA} dB(A)
300 × 8	7	26	1	<15	1	<15	1	<15
	35	126	15	23	18	22	30	24
	60	216	45	39	53	38	87	40
	85	306	91	50	105	50	174	51
400 × 16	13	46	1	<15	1	<15	1	<15
	60	216	13	22	15	23	28	25
	100	360	36	38	42	39	78	42
	140	504	71	50	83	50	154	54
500 × 24	19	70	1	<15	1	<15	3	<15
	70	252	11	19	14	19	34	24
	125	450	35	38	45	37	108	42
	175	630	68	50	89	49	212	54
600 × 24, 625 × 24	28	102	1	<15	1	<15	2	<15
	105	378	11	20	15	21	33	22
	165	594	26	34	37	34	83	36
	260	936	65	50	91	51	205	55
600 × 48	40	145	1	<15	2	<15	5	<15
	130	468	12	21	18	23	50	29
	210	756	32	37	47	40	131	45
	305	1098	67	50	98	55	276	60
625 × 54	52	186	2	<15	2	<15	7	<15
	140	504	13	22	16	24	48	33
	225	810	34	38	41	39	125	51
	310	1116	64	50	77	52	238	64
825 × 72	99	357	2	<15	4	<15	10	<15
	225	810	13	24	21	27	51	33
	400	1440	41	44	65	49	161	54
	470	1692	56	50	90	57	222	61

- Selection tables provide a good overview of the volume flow rates and corresponding sound power levels and differential pressures.
- The minimum volume flow rates apply to a supply air to room air temperature difference of –6 K.
- The maximum volume flow rates apply to a sound power level of approx. 50 dB (A) with damper blade position 0°.

SWD224 SELECTION TABLE

SWIRL DIFFUSER

Q _v (m ³ /h)	MODEL	310	400	500	600	800
200	Lt (m)	1,1				
	Vt (m/s)	0,2				
	NR	27				
	P (Pa)	25				
300	Lt (m)	1,8	1			
	Vt (m/s)	0,2	0,2			
	NR	37	33			
	P (Pa)	50	40			
400	Lt (m)	2,8	1,5			
	Vt (m/s)	0,2	0,2			
	NR	42	40			
	P (Pa)	80	70			
500	Lt (m)	2	2,5	1,5		
	Vt (m/s)	0,25	0,2	0,2		
	NR	50	45	35		
	P (Pa)	140	110	30		
600	Lt (m)			2	1,5	
	Vt (m/s)			0,2	0,2	
	NR			37	35	
	P (Pa)			40	30	
800	Lt (m)			2,5	2	
	Vt (m/s)			0,2	0,2	
	NR			45	35	
	P (Pa)			70	38	
1000	Lt (m)			2,5	1,5	1,8
	Vt (m/s)			0,25	0,25	0,2
	NR			50	40	30
	P (Pa)			100	50	20
1500	Lt (m)				3	3
	Vt (m/s)				0,3	0,2
	NR				45	40
	P (Pa)				80	40
2000	Lt (m)					4
	Vt (m/s)					0,2
	NR					47
	P (Pa)					80
2500	Lt (m)					4
	Vt (m/s)					0,25
	NR					52
	P (Pa)					100

SELECTION CRITERIAS

$L=L_1+H_1$
 $H_1=1,2mt$
 Ceiling height 3m
 Ceiling effect
 Louvers Position "B"

Lt(m) : Throw Distance
 NR : Sound Level
 Pt(Pa) : Pressure Drop
 Vk(m/s): Slot Output Speed

SWD324 SELECTION TABLE

Q _v (m ³ /h)	MODEL	310	400	500	600	800
200	Lt (m)	1				
	Vt (m/s)	0,2				
	NR	25				
	P (Pa)	22				
300	Lt (m)	2	1,2			
	Vt (m/s)	0,2	0,2			
	NR	35	33			
	P (Pa)	45	40			
400	Lt (m)	3	2			
	Vt (m/s)	0,2	0,2			
	NR	45	40			
	P (Pa)	90	65			
500	Lt (m)	3	2,5	1,3		
	Vt (m/s)	0,25	0,2	0,2		
	NR	50	45	30		
	P (Pa)	140	100	19		
600	Lt (m)			2	1,5	
	Vt (m/s)			0,2	0,2	
	NR			35	25	
	P (Pa)			28	18	
800	Lt (m)			2,5	2	
	Vt (m/s)			0,2	0,2	
	NR			40	35	
	P (Pa)			45	35	
1000	Lt (m)			3	3	1,5
	Vt (m/s)			0,2	0,2	0,2
	NR			45	40	25
	P (Pa)			65	50	15
1500	Lt (m)				4	2,5
	Vt (m/s)				0,2	0,2
	NR				50	35
	P (Pa)				100	30
2000	Lt (m)					3,5
	Vt (m/s)					0,2
	NR					43
	P (Pa)					55
2500	Lt (m)					4,5
	Vt (m/s)					0,2
	NR					50
	P (Pa)					80

SELECTION CRITERIAS

$$L=L_t+H_1$$

$$H_1=1,2\text{mt}$$

Ceiling height 3m

Ceiling effect

Louvre Positions "B"

Lt(m) : Throw Distance
 NR : Sound Level
 Pt(Pa) : Pressure Drop



SWIRL DIFFUSER

Vk(m/s): Slot Output Speed

imperial System

RSD RADIAL SLOT DIFFUSER

12 in. x 12 in. - Circular Array

Inlet Size	Neck Velocity (fpm) Velocity Pressure (in. w.g.)	200 0.002	300 0.006	400 0.010	500 0.016	600 0.022	700 0.031	800 0.040	900 0.050	1000 0.062	1200 0.090
6"ø	Static Pressure (in. w.g.)	0.014	0.029	0.048	0.071	0.098	0.128	0.163	0.200	0.241	0.333
	Flow Rate (cfm)	39	59	79	98	118	137	157	177	196	236
	Sound (NC)	-	-	-	18	23	27	30	33	36	41
	Throw (ft.)	0 - 1 - 2	1 - 1 - 3	1 - 2 - 4	2 - 3 - 6	2 - 3 - 7	3 - 4 - 7	3 - 4 - 8	3 - 5 - 8	4 - 6 - 9	4 - 7 - 10

24 in. x 24 in. - Circular Array

Inlet Size	Neck Velocity (fpm) Velocity Pressure (in. w.g.)	200 0.002	300 0.006	400 0.010	500 0.016	600 0.022	700 0.031	800 0.040	900 0.050	1000 0.062	1200 0.090
8"ø	Static Pressure (in. w.g.)	0.006	0.013	0.022	0.032	0.045	0.059	0.075	0.093	0.112	0.155
	Flow Rate (cfm)	70	105	140	175	209	244	279	314	349	419
	Sound (NC)	-	-	-	-	16	21	25	28	31	36
	Throw (ft.)	1-1-2	1-2-3	1-2-4	2-3-6	2-3-7	3-4-8	3-4-9	3-5-10	4-6-11	4-7-12
10"ø	Static Pressure (in. w.g.)	0.013	0.027	0.045	0.067	0.092	0.122	0.155	0.191	0.231	
	Flow Rate (cfm)	109	164	218	273	327	382	436	491	545	
	Sound (NC)	-	-	18	24	29	33	37	41	44	
	Throw (ft.)	1-2-3	2-3-5	2-3-7	3-4-9	3-5-10	4-6-11	5-7-12	5-8-13	6-9-14	
12"ø	Static Pressure (in. w.g.)	0.025	0.052	0.086	0.129	0.178	0.235	0.298			
	Flow Rate (cfm)	157	236	314	393	471	550	628			
	Sound (NC)	-	20	28	34	39	44	48			
	Throw (ft.)	2-3-5	3-4-8	3-5-10	4-6-11	5-8-13	6-9-14	7-10-15			

24 in. x 24 in. - Square Array

Inlet Size	Neck Velocity (fpm) Velocity Pressure (in. w.g.)	200 0.002	300 0.006	400 0.010	500 0.016	600 0.022	700 0.031	800 0.040	900 0.050	1000 0.062	1200 0.090
8"ø	Static Pressure (in. w.g.)	0.006	0.013	0.021	0.030	0.041	0.054	0.067	0.083	0.099	0.135
	Flow Rate (cfm)	70	105	140	175	209	244	279	314	349	419
	Sound (NC)	-	-	-	-	17	21	25	28	31	36
	Throw (ft.)	0-0-2	0-1-3	1-2-4	1-2-6	2-3-7	2-4-8	3-4-9	3-5-10	4-6-11	4-7-13
10"ø	Static Pressure (in. w.g.)	0.011	0.022	0.038	0.057	0.079	0.105	0.134	0.167	0.202	
	Flow Rate (cfm)	109	164	218	273	327	382	436	491	545	
	Sound (NC)	-	-	18	24	29	34	37	41	44	
	Throw (ft.)	0-1-3	1-2-5	2-3-7	3-4-9	3-5-10	4-6-12	5-7-13	5-8-14	6-9-15	
12"ø	Static Pressure (in. w.g.)	0.026	0.053	0.089	0.132	0.182	0.239	0.303			
	Flow Rate (cfm)	157	236	314	393	471	550	628			
	Sound (NC)	-	20	28	34	39	44	48			
	Throw (ft.)	1-2-5	2-4-8	3-5-10	4-6-12	5-8-14	6-9-15	7-10-16			

Performance Notes:

1. Tested in accordance with ASHRAE Standard 70 - 2006 "Method of Testing for Rating the Performance of Air, Outlets and Inlets.
2. Airflow is in cubic feet per minute [cfm].
3. NC, sound pressure levels, are based on a room absorption of 10 dB re 10-12 Watts, and a single diffuser/grille.
4. Blanks "-" indicate an NC level below 15.
5. All pressures are in inches of water column [in. w.g.].
6. Pressures not listed can be calculated using the following formula: $P_{total} = P_{static} + P_{velocity}$
7. Throw data is based on supply air and room air being at isothermal conditions
8. Throw data is given in feet [ft] to terminal velocities of

SWIRL DIFFUSER

- 150 fpm (minimum)
- 100 fpm (middle)
- 50 fpm (maximum)

INSTALLATION DETAILS:

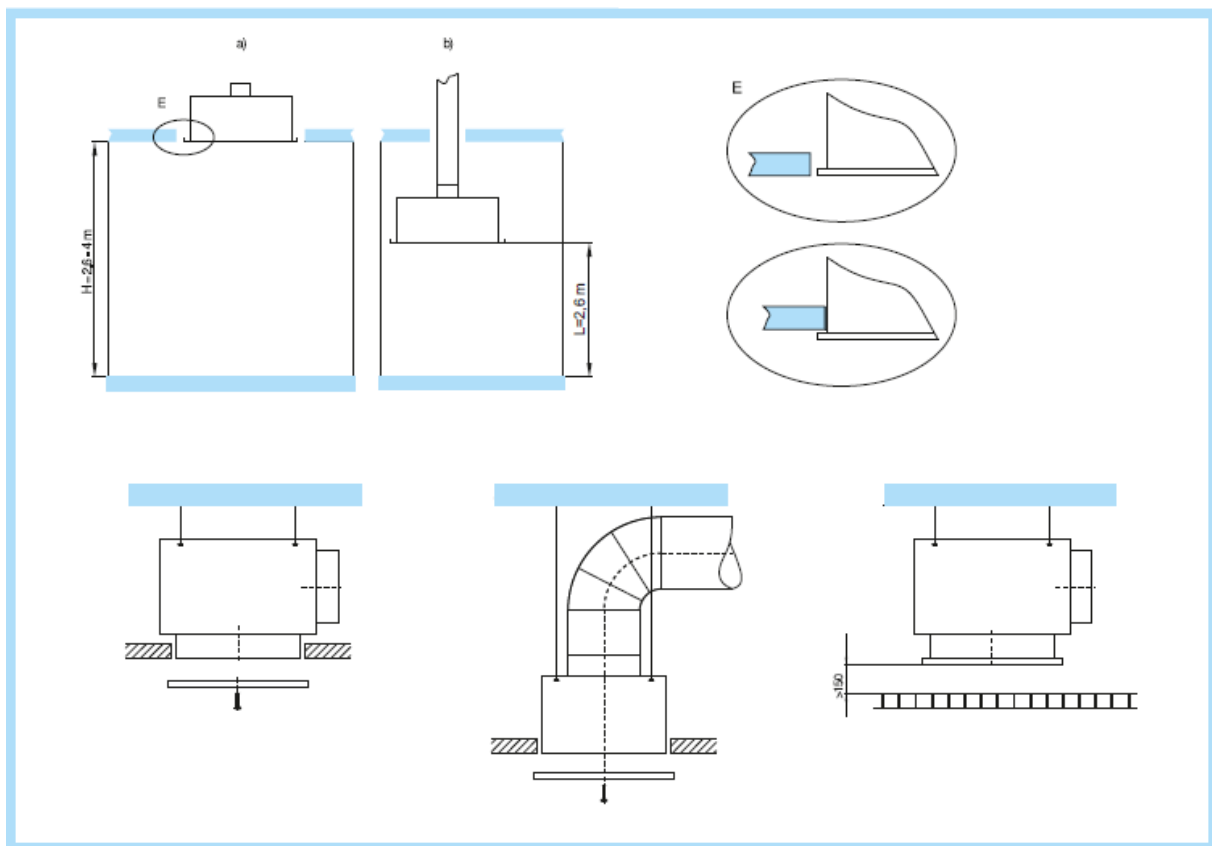

Diffuser face – sealing

Diffuser face – central screw fixing

SWIRL DIFFUSER

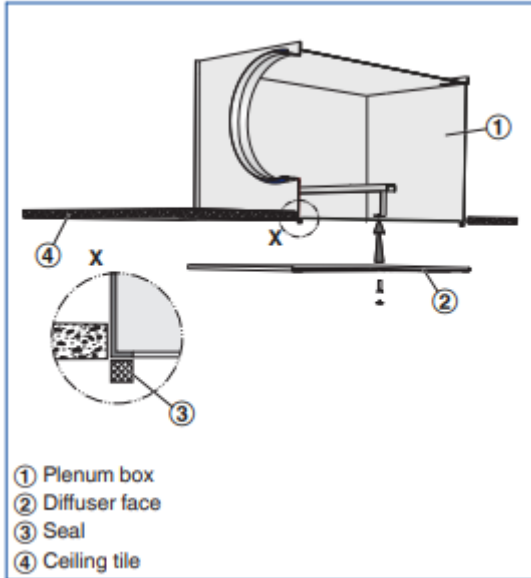

- The self-adhesive sealing tape (supplied) has to be applied to the return edges of the plenum box by others

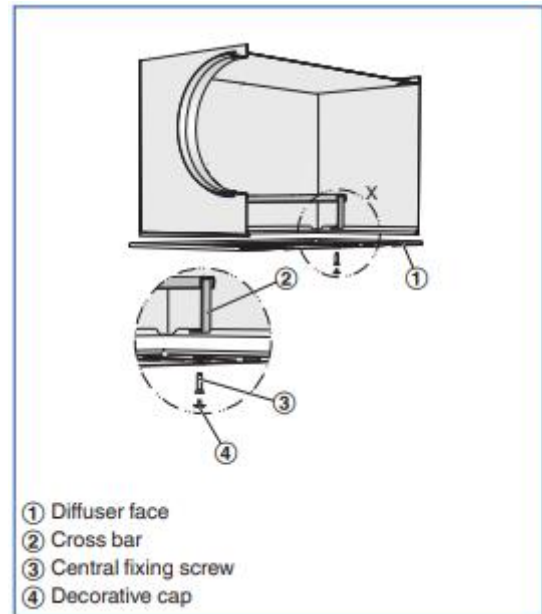

- Using the central fixing screw, fix the diffuser face to the cross bar of the plenum box
- Attach the decorative cap

Ceiling systems

Installation into grid ceilings

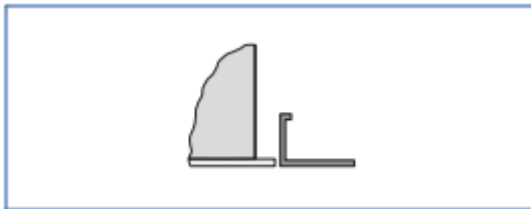

- Fix the plenum box to the ceiling
- The ceiling tile of the grid ceiling is independent of the ceiling diffuser
- Fix the diffuser face after the ceiling has been completed

Installation in continuous ceilings



- Fix plenum box (including diffuser face, if necessary) to the ceiling
- Adjust plasterboard ceiling tile as required
- If necessary, fix the diffuser face after the ceiling has been completed

Installation in T-bar ceilings

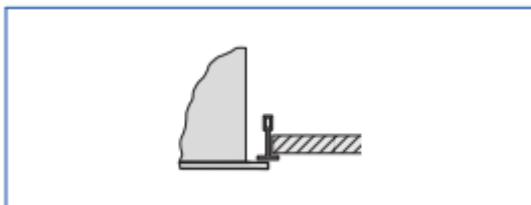

- Fix the plenum box to the ceiling
- The T-bar ceiling is independent of the ceiling diffuser
- Fix the diffuser face below the T-bars after the ceiling has been completed



SWIRL DIFFUSER

ORDER CODES

SWD-124	SQF	RAL9010	SM	F 595x595
SWD-124 SWD-224 SWD-324 RSD				(out size) F: Frame Size
CRF: Circular Frame SQF: Rectangular Frame				00: No Mounting SM: Screw Mounting BM: Bridge Mounting 00: No coating EX: Eloxal Coating RAL----: Oven Drying Coating